

Precision Air-Core Tach/Speedo Driver with Separate Function Generator Input

Description

The CS4101 is specifically designed for use with air-core meter movements. The IC provides all the functions necessary for an analog tachometer or speedometer. The CS4101 takes a speed sensor input and generates sine and cosine related output signals to differentially drive an air-core meter.

Many enhancements have been added over industry standard

tachometer drivers such as the CS289 or LM1819. The output utilizes differential drivers which eliminates the need for a zener reference and offers more torque. The device withstands 60V transients which decreases the protection circuitry required. The device is also more precise than existing devices allowing for fewer trims and for use in a speedometer.

Features

- Direct Sensor Input
- High Output Torque
- Low Pointer Flutter
- High Input Impedance
- Overvoltage Protection

Absolute Maximum Ratings

Supply Voltage (<100ms pulse transient)	V _{CC} = 60V
(continuous)	V _{CC} = 24V
Operating Temperature	-40°C to +105°C
Storage Temperature	-40°C to +165°C
Junction Temperature	-40°C to +150°C
ESD (Human Body Model)	4kV
Lead Temperature Soldering	
Wave Solder(through hole styles only)	10 sec. max, 260°C peak

Block Diagram

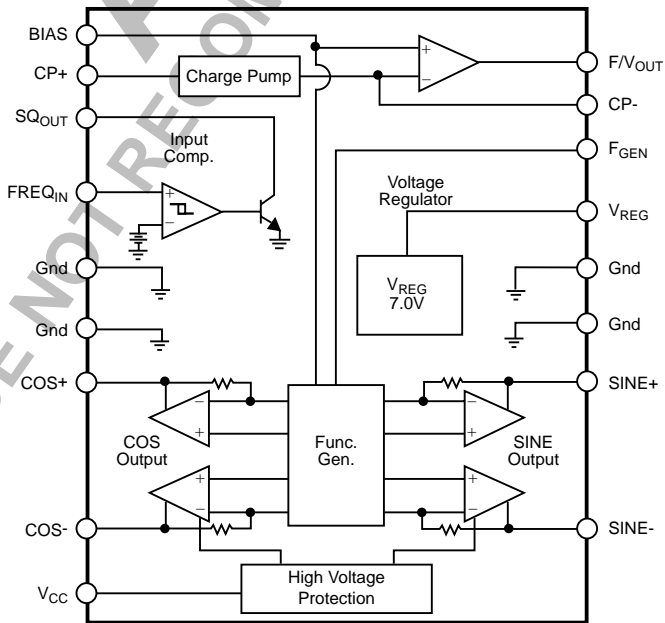

Package Option

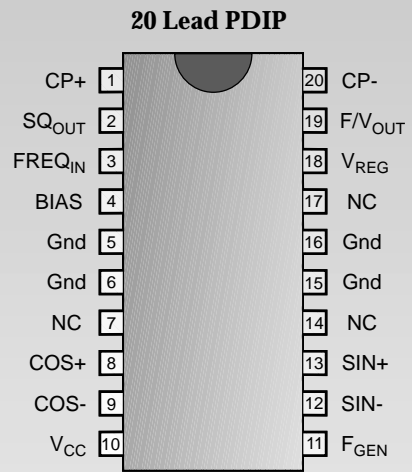

Electrical Characteristics: $-40^{\circ}\text{C} \leq T_A \leq 85^{\circ}\text{C}$, $8.5\text{V} \leq V_{CC} \leq 15\text{V}$ unless otherwise specified.

PARAMETER	TEST CONDITIONS	MIN	TYP	MAX	UNIT
■ Supply Voltage Section					
I_{CC} Supply Current	$V_{CC} = 16\text{V}$, -40°C , No Load		50	125	mA
V_{CC} Normal Operation Range		8.5	13.1	16.0	V
■ Input Comparator Section					
Positive Input Threshold		2.4	3.4	4.4	V
Input Hysteresis		200	400		mV
Input Bias Current *	$0\text{V} \leq V_{IN} \leq 8\text{V}$		-10	-80	μA
Input Frequency Range		0		20	KHz
Input Voltage Range	in series with $1\text{k}\Omega$	-1		V_{CC}	V
Output V_{SAT}	$I_{CC} = 10\text{mA}$		0.15	0.40	V
Output Leakage	$V_{CC} = 7\text{V}$			10	μA
Low V_{CC} Disable Threshold		7.0	8.0	8.5	V
Logic 0 Input Voltage		2.4			V

*Note: Input is clamped by an internal 12V Zener.

■ Voltage Regulator Section

Output Voltage		6.25	7.00	7.50	V
Output Load Current				10	mA
Output Load Regulation	0 to 10 mA		10	50	mV
Output Line Regulation	$8.5\text{V} \leq V_{CC} \leq 16\text{V}$		20	150	mV
Power Supply Rejection	$V_{CC} = 13.1\text{V}$, 1Vp/p 1kHz	34	46		dB

■ Charge Pump Section

Inverting Input Voltage		1.5	2.0	2.5	V
Input Bias Current			40	150	nA
V_{bias} Input Voltage		1.5	2.0	2.5	V
Non Invert. Input Voltage	$I_{IN} = 1\text{mA}$		0.7	1.1	V
Linearity*	@ 0, 87.5, 175, 262.5, + 350Hz	-0.10	0.28	+0.70	%
F/ V_{OUT} Gain	@ 350Hz, $C_T = 0.0033\mu\text{F}$, $R_T = 243\text{k}\Omega$	7	10	13	mV/Hz
Norton Gain, Positive	$I_{IN} = 15\mu\text{A}$	0.9	1.0	1.1	I/I
Norton Gain, Negative	$I_{IN} = 15\mu\text{A}$	0.9	1.0	1.1	I/I

*Note: Applies to % of full scale (270°).

■ Function Generator Section: $-40^{\circ} \leq T_A \leq 85^{\circ}\text{C}$, $V_{CC} = 13.1\text{V}$ unless otherwise noted.

Differential Drive Voltage ($V_{COS+} - V_{COS-}$)	$8.5\text{V} \leq V_{CC} \leq 16\text{V}$ $\Theta = 0^{\circ}$	5.5	6.5	7.5	V
Differential Drive Voltage ($V_{SIN+} - V_{SIN-}$)	$8.5\text{V} \leq V_{CC} \leq 16\text{V}$ $\Theta = 90^{\circ}$	5.5	6.5	7.5	V
Differential Drive Voltage ($V_{COS+} - V_{COS-}$)	$8.5\text{V} \leq V_{CC} \leq 16\text{V}$ $\Theta = 180^{\circ}$	-7.5	-6.5	-5.5	V
Differential Drive Voltage ($V_{SIN+} - V_{SIN-}$)	$8.5\text{V} \leq V_{CC} \leq 16\text{V}$ $\Theta = 270^{\circ}$	-7.5	-6.5	-5.5	V
Differential Drive Current	$8.5\text{V} \leq V_{CC} \leq 16\text{V}$		33	42	mA
Zero Hertz Output Angle		-1.5	0.0	1.5	deg
Function Generator Error * Reference Figures 1,2,3,4	$V_{CC} = 13.1\text{V}$ $\Theta = 0^{\circ}$ to 305°	-2	0	+2	deg

* Note: Deviation from nominal per Table 1 after calibration at 0 and 270°.

PARAMETER	TEST CONDITIONS	MIN	TYP	MAX	UNIT
Function Generator Section: continued					
Function Generator Error	$13.1\text{V} \leq V_{CC} \leq 16\text{V}$	-2.5	0	+2.5	deg
Function Generator Error	$13.1\text{V} \leq V_{CC} \leq 11\text{V}$	-1	0	+1	deg
Function Generator Error	$13.1\text{V} \leq V_{CC} \leq 9\text{V}$	-3	0	+3	deg
Function Generator Error	$25^{\circ}\text{C} \leq T_A \leq 80^{\circ}\text{C}$	-3	0	+3	deg
Function Generator Error	$25^{\circ}\text{C} \leq T_A \leq 105^{\circ}\text{C}$	-5.5	0	+5.5	deg
Function Generator Error	$-40^{\circ}\text{C} \leq T_A \leq 25^{\circ}\text{C}$	-3	0	+3	deg
Function Generator Gain	$T_A = 25^{\circ}\text{C} \Theta$ vs F/V_{OUT}	60	77	95	$^{\circ}/\text{V}$

Package Lead Description

PACKAGE LEAD #	LEAD SYMBOL	FUNCTION
20L		
1	CP+	Positive input to charge pump.
2	SQ _{OUT}	Buffered square wave output signal.
3	FREQ _{IN}	Speed or rpm input signal.
4	BIAS	Test point or Zero adjustment.
5, 6, 15, 16	Gnd	Ground Connections.
7, 14, 17	NC	No Connection.
8	COS+	Positive cosine output signal.
9	COS-	Negative cosine output signal.
10	V _{CC}	Ignition or battery supply voltage.
11	F _{GEN}	Function generator input signal.
12	SIN-	Negative sine output signal.
13	SIN+	Positive sine output signal.
18	V _{REG}	Voltage regulator output.
19	F/V _{OUT}	Output voltage proportional to input signal frequency.
20	CP-	Negative input to charge pump.

Typical Performance Characteristics

Figure 1: Function Generator Output Voltage vs Degrees of Deflection

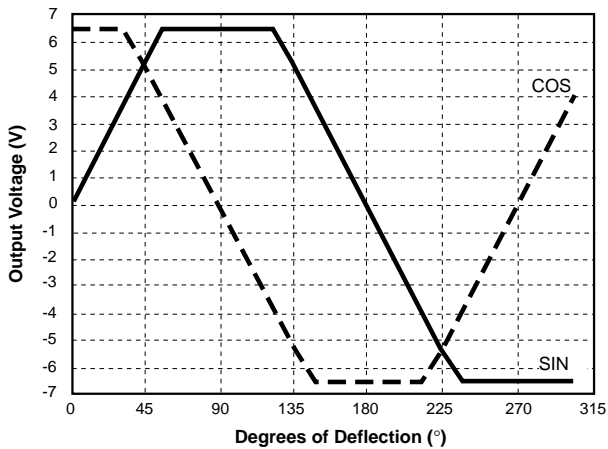
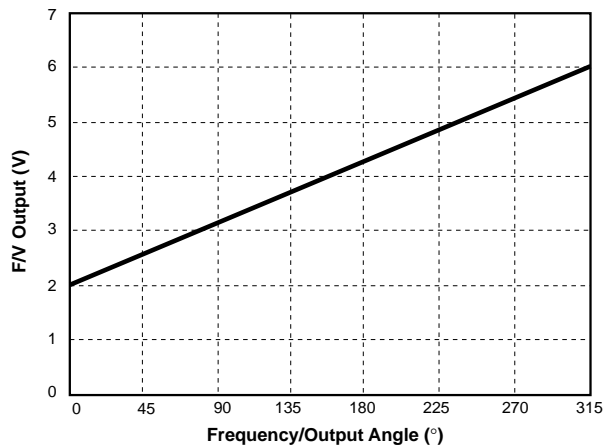

Figure 2: Charge Pump Output Voltage vs Output Angle

$$F/V_{OUT} = 2.0\text{V} + 2 \text{ FREQ} \times C_T \times R_T \times (V_{REG} - 0.7)$$



Typical Performance Characteristics continued

Figure 3: Output Angle in Polar Form

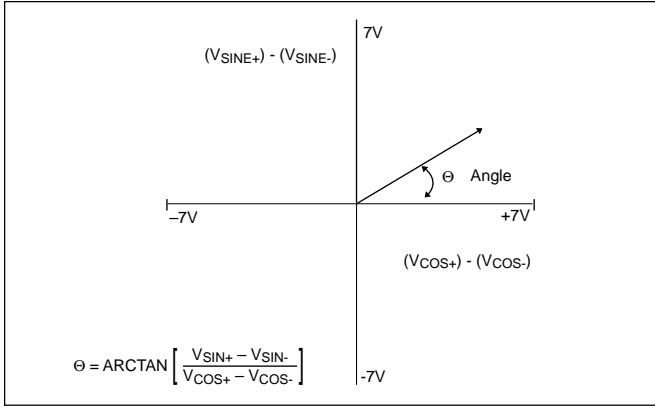
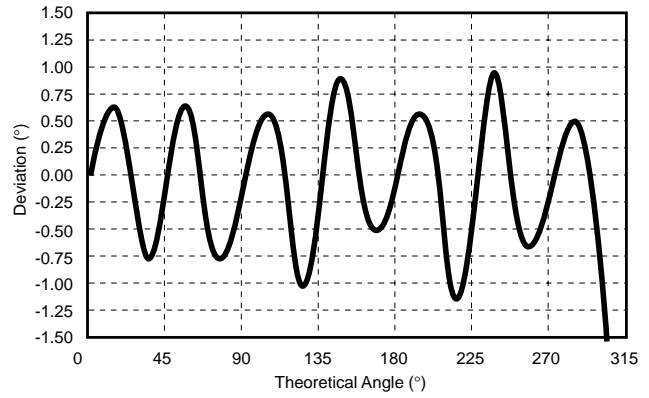

Figure 4: Nominal Output Deviation



Nominal Angle vs. Ideal Angle (After calibrating at 180°)

Note: Temperature, voltage and nonlinearity not included.

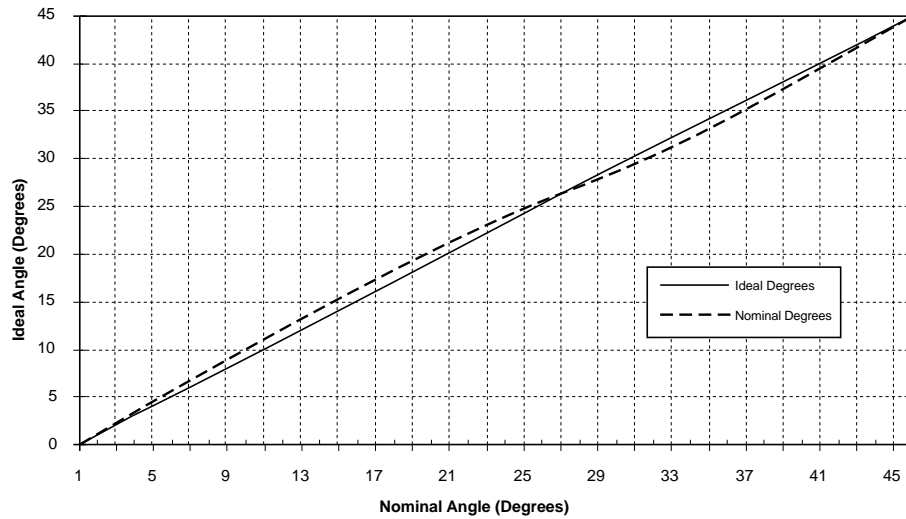

Table 1: Function Generator Output Nominal Angle vs. Ideal Angle (After calibrating at 270°)

Ideal θ Degrees	Nominal θ Degrees	Ideal θ Degrees	Nominal θ Degrees	Ideal θ Degrees	Nominal θ Degrees	Ideal θ Degrees	Nominal θ Degrees	Ideal θ Degrees	Nominal θ Degrees	Ideal θ Degrees	Nominal θ Degrees
0	0	17	17.98	34	33.04	75	74.00	160	159.14	245	244.63
1	1.09	18	18.96	35	34.00	80	79.16	165	164.00	250	249.14
2	2.19	19	19.92	36	35.00	85	84.53	170	169.16	255	254.00
3	3.29	20	20.86	37	36.04	90	90.00	175	174.33	260	259.16
4	4.38	21	21.79	38	37.11	95	95.47	180	180.00	265	264.53
5	5.47	22	22.71	39	38.21	100	100.84	185	185.47	270	270.00
6	6.56	23	23.61	40	39.32	105	106.00	190	190.84	275	275.47
7	7.64	24	24.50	41	40.45	110	110.86	195	196.00	280	280.84
8	8.72	25	25.37	42	41.59	115	115.37	200	200.86	285	286.00
9	9.78	26	26.23	43	42.73	120	119.56	205	205.37	290	290.86
10	10.84	27	27.07	44	43.88	125	124.00	210	209.56	295	295.37
11	11.90	28	27.79	45	45.00	130	129.32	215	214.00	300	299.21
12	12.94	29	28.73	50	50.68	135	135.00	220	219.32	305	303.02
13	13.97	30	29.56	55	56.00	140	140.68	225	225.00		
14	14.99	31	30.39	60	60.44	145	146.00	230	230.58		
15	16.00	32	31.24	65	64.63	150	150.44	235	236.00		
16	17.00	33	32.12	70	69.14	155	154.63	240	240.44		

Note: Temperature, voltage and nonlinearity not included.

The CS4101 is specifically designed for use with air-core meter movements. It includes an input comparator for sensing an input signal from an ignition pulse or speed sensor, a charge pump for frequency to voltage conversion, a bandgap voltage regulator for stable operation, and a function generator with sine and cosine amplifiers to differentially drive the motor coils.

From the simplified block diagram of Figure 5A, the input signal is applied to the $FREQ_{IN}$ lead, this is the input to a high impedance comparator with a typical positive input threshold of 3.4V and typical hysteresis of 0.4V. The output of the comparator, SQ_{OUT} , is applied to the charge pump input $CP+$ through an external capacitor C_T . When the input signal changes state, C_T is charged or discharged through R_3 and R_4 . The charge accumulated on C_T is mirrored to C_4 by the Norton Amplifier circuit comprising Q_1 , Q_2 and Q_3 . The charge pump output voltage, F/V_{OUT} , ranges from 2V to 6.3V depending on the input signal frequency and the gain of the charge pump according to the formula:

$$F/V_{OUT} = 2.0V + 2 \times FREQ \times C_T \times R_T \times (V_{REG} - 0.7V)$$

R_T is a potentiometer used to adjust the gain of the F/V output stage and give the correct meter deflection. The F/V output voltage is applied to the function generator input lead, F_{GEN} . An additional filter circuit can be added between F/V_{OUT} and F_{GEN} to reduce needle flutter. The output voltage of the sine and cosine amplifiers are derived from the on-chip amplifier and function generator circuitry. The various trip points for the circuit (i.e., 0°, 90°, 180°, 270°) are determined by an internal resistor divider, and the bandgap voltage reference. The coils are differentially driven, allowing bidirectional current flow in the outputs, thus providing up to 305° range of meter deflection. Driving the coils differentially offers faster response time, higher current capability, higher output voltage swings, and reduced external component count. The key advantage is a higher torque output for the pointer.

The output angle, Θ , is equal to the F/V gain multiplied by the function generator gain:

$$\Theta = A_{F/V} \times A_{FG},$$

where:

$$A_{FG} = 77^\circ/V \text{ (typ)}$$

The relationship between input frequency and output angle is:

$$\Theta = A_{FG} \times 2 \times FREQ \times C_T \times R_T \times (V_{REG} - 0.7V)$$

$$\text{or, } \Theta = 970 \times FREQ \times C_T \times R_T$$

The ripple voltage at the F/V converter's output is determined by the ratio of C_T and C_4 in the formula:

$$\Delta V = \frac{C_T(V_{REG} - 0.7V)}{C_4}$$

Ripple voltage on the F/V output causes pointer or needle flutter especially at low input frequencies.

The response time of the F/V is determined by the time constant formed by R_T and C_4 . Increasing the value of C_4 will reduce the ripple on the F/V output but will also increase the response time. An increase in response time causes a very slow meter movement and may be unacceptable for many applications.

Design Example

Maximum meter Deflection = 270°

Maximum Input Frequency = 350Hz

1. Select R_T and C_T

$$\Theta = A_{GEN} \times \Delta_{F/V}$$

$$\Delta_{F/V} = 2 \times FREQ \times C_T \times R_T \times (V_{REG} - 0.7V)$$

$$\Theta = 970 \times FREQ \times C_T \times R_T$$

Let $C_T = 0.0033\mu F$, Find R_T

$$R_T = \frac{270^\circ}{970 \times 350\text{Hz} \times 0.0033\mu F}$$

$$R_T = 243\text{k}\Omega$$

R_T should be a 250k Ω potentiometer to trim out any inaccuracies due to IC tolerances or meter movement pointer placement.

2. Select R_3 and R_4

Resistor R_3 sets the output current from the voltage regulator. The maximum output current from the voltage regulator is 10mA R_3 must ensure that the current does not exceed this limit.

Choose $R_3 = 3.3\text{k}\Omega$

The charge current for C_T is:

$$\frac{V_{REG} - 0.7V}{3.3\text{k}\Omega} = 1.90\text{mA}$$

C_1 must charge and discharge fully during each cycle of the input signal. Time for one cycle at maximum frequency is 2.85ms. To ensure that C_T is discharged, assume that the $(R_3 + R_4)C_T$ time constant is less than 10% of the minimum input frequency pulse width.

$$T = 285\mu s$$

Choose $R_4 = 1\text{k}\Omega$.

Charge time: $T = R_3 \times C_T = 3.3\text{k}\Omega \times 0.0033\mu F = 10.9\mu s$

Discharge time: $T = (R_3 + R_4)C_T = 4.3\text{k}\Omega \times 0.0033\mu F = 14.2\mu s$

3. Determine C_4

C_4 is selected to satisfy both the maximum allowable ripple voltage and response time of the meter movement.

$$C_4 = \frac{C_T(V_{REG} - 0.7V)}{V_{RIPPLE(MAX)}}$$

With $C_4 = 0.47\mu F$, the F/V ripple voltage is 44mV.

Figure 7 shows how the CS4101 and the CS-8441 are used to produce a speedometer and odometer circuit.

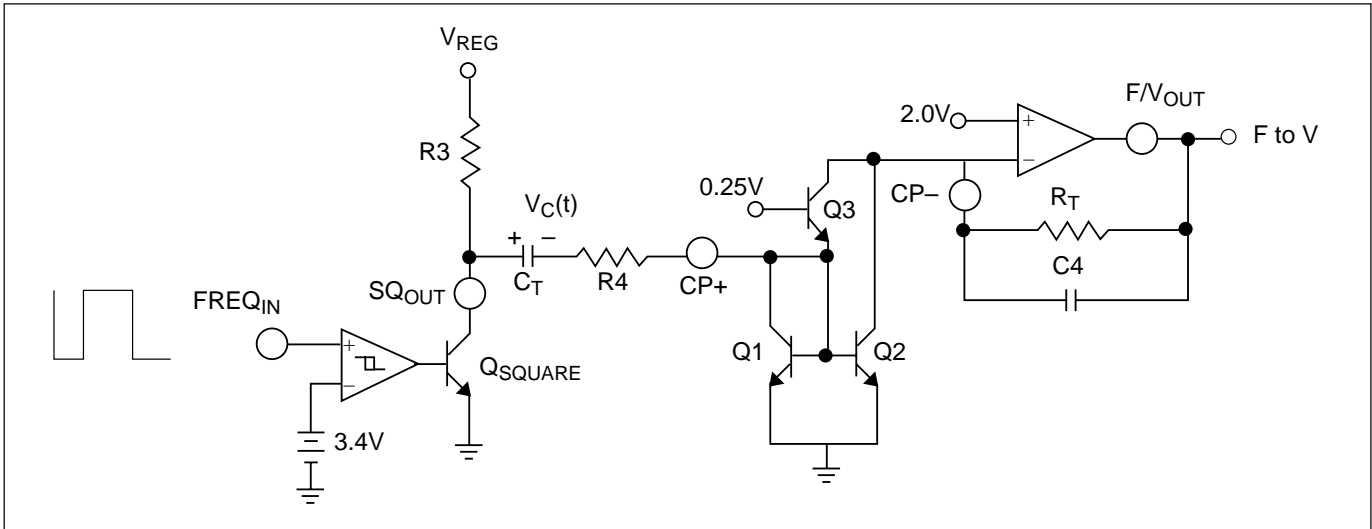

Figure 5A: Partial Schematic of Input and Charge Pump

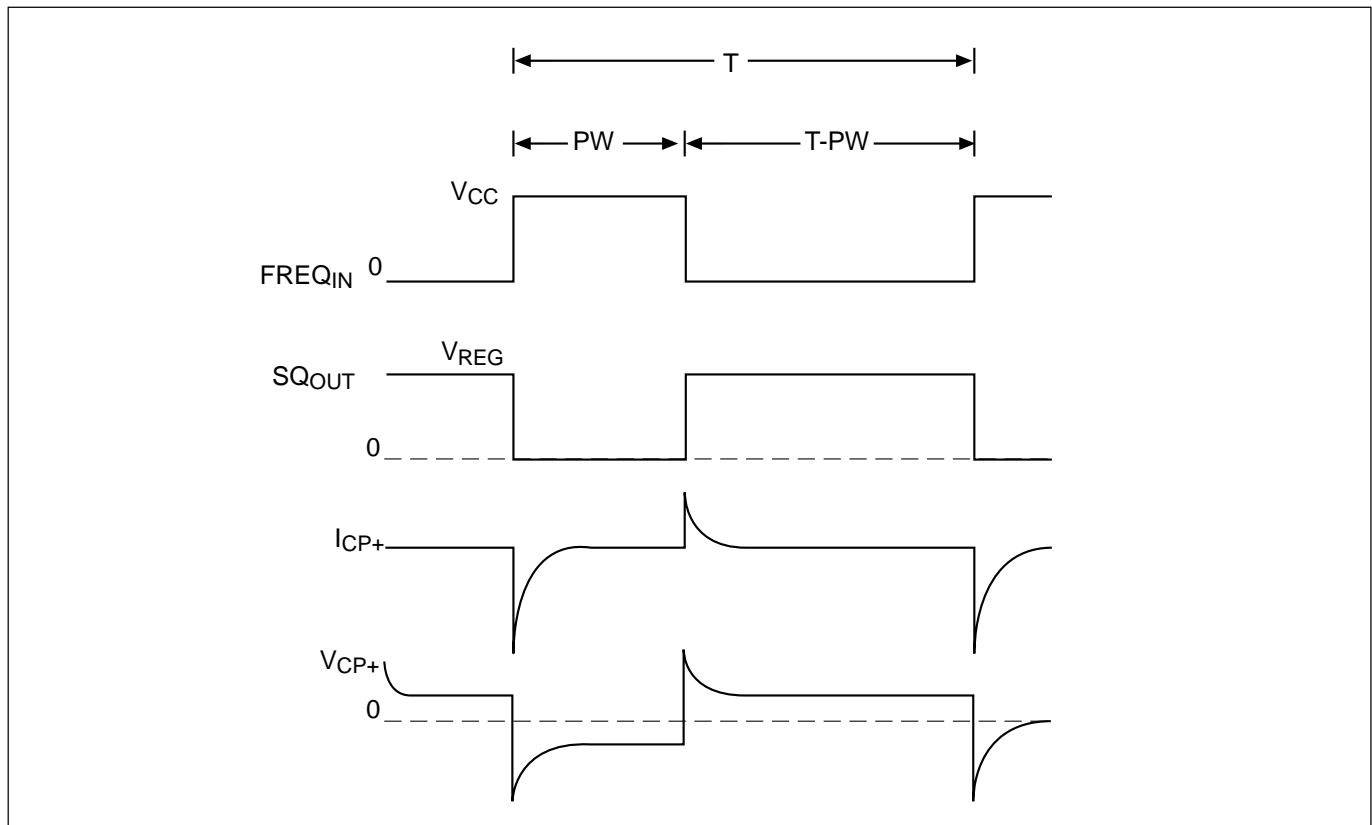

Figure 5B: Timing Diagram of $FREQ_{IN}$ and I_{CP}

Speedometer/Odometer or Tachometer Application

CS4101

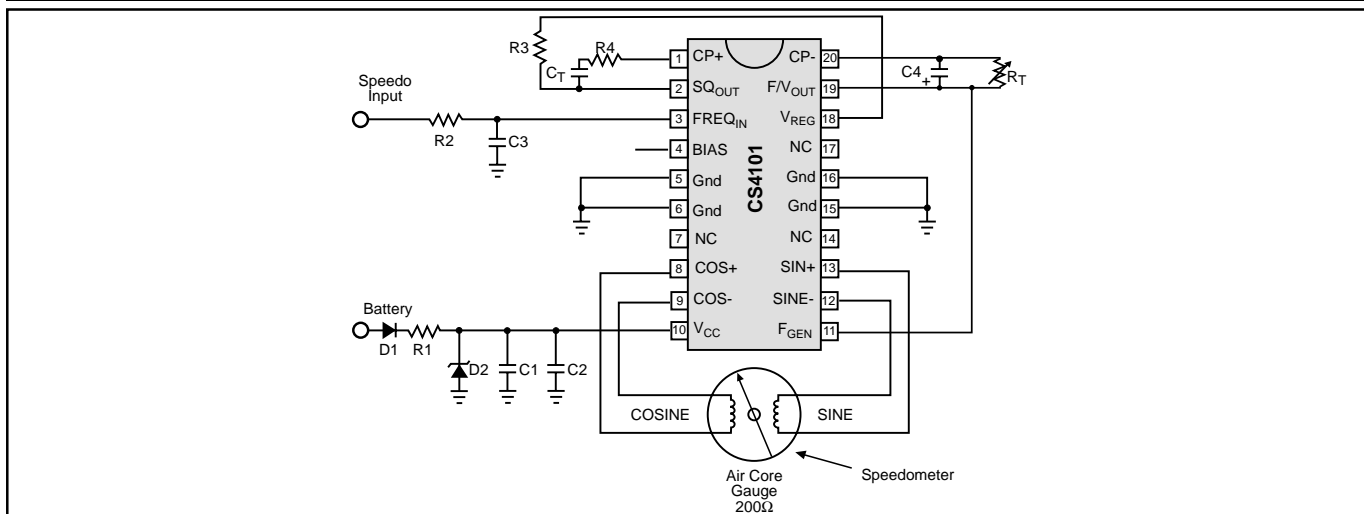

Figure 6

R1 - 3.9, 500mW

R2 - 10kΩ

R3 - 3kΩ

R4 - 1kΩ

R_T - Trim Resistor +/- 20 PPM/DEG. C

C1 - 0.1μF

C2 - 1. Stand alone Speedo or Tach "0" μF

2. Stand alone Speedo or Tach with return to Zero, 2000μF

3. With CS-8441 application, 10μF

C3 - 0.1μF

C4 - 0.47μF

C_T - 0.0033μF, +/- 30 PPM/°C

D1 - 1A, 600 PIV

D2 - 50V, 500mW Zener

Note 1: For 58% Speed Input $T_{MAX} \leq 5/f_{MAX}$ where

$$T_{MAX} = C_T(R_3+R_4)$$

f_{MAX} = maximum speed input frequency

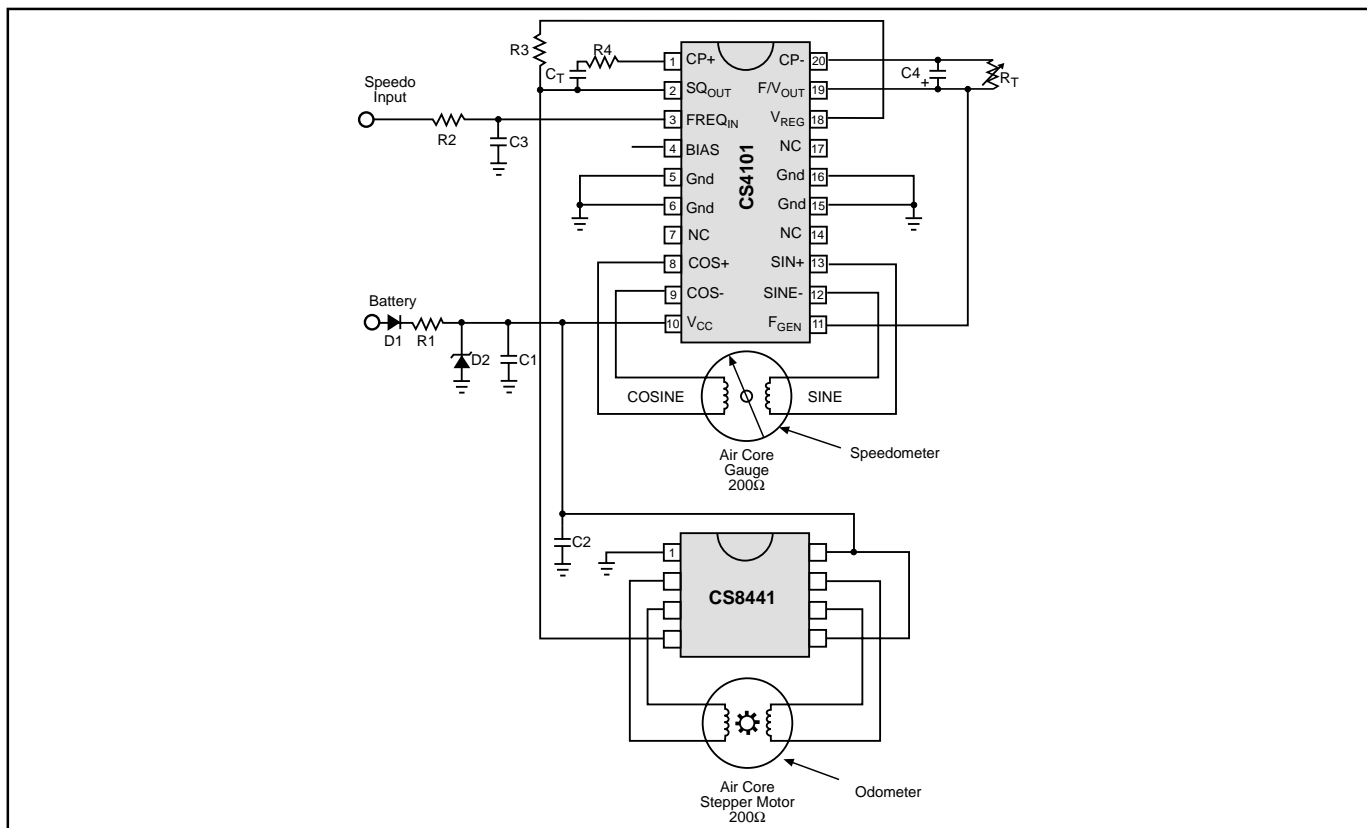

Figure 7

Note 1: The product of C_T and R_T have a direct effect on gain and therefore directly effect temperature compensation

Note 2: C4 Range; 20pF to .2μF

Note 3: R4 Range; 100kΩ to 500kΩ

Note 4: The IC must be protected from transients above 60V and reverse battery conditions

Note 5: Additional filtering on the FREQ_{IN} lead may be required

Package Specification

PACKAGE DIMENSIONS IN mm (INCHES)

Lead Count	D			
	Metric		English	
	Max	Min	Max	Min
20 Lead PDIP	26.92	24.89	1.060	.980

PACKAGE THERMAL DATA

Thermal Data		20L PDIP	
$R_{\theta JC}$	typ	25	$^{\circ}C/W$
$R_{\theta JA}$	typ	65	$^{\circ}C/W$

Plastic DIP (N); 300 mil wide

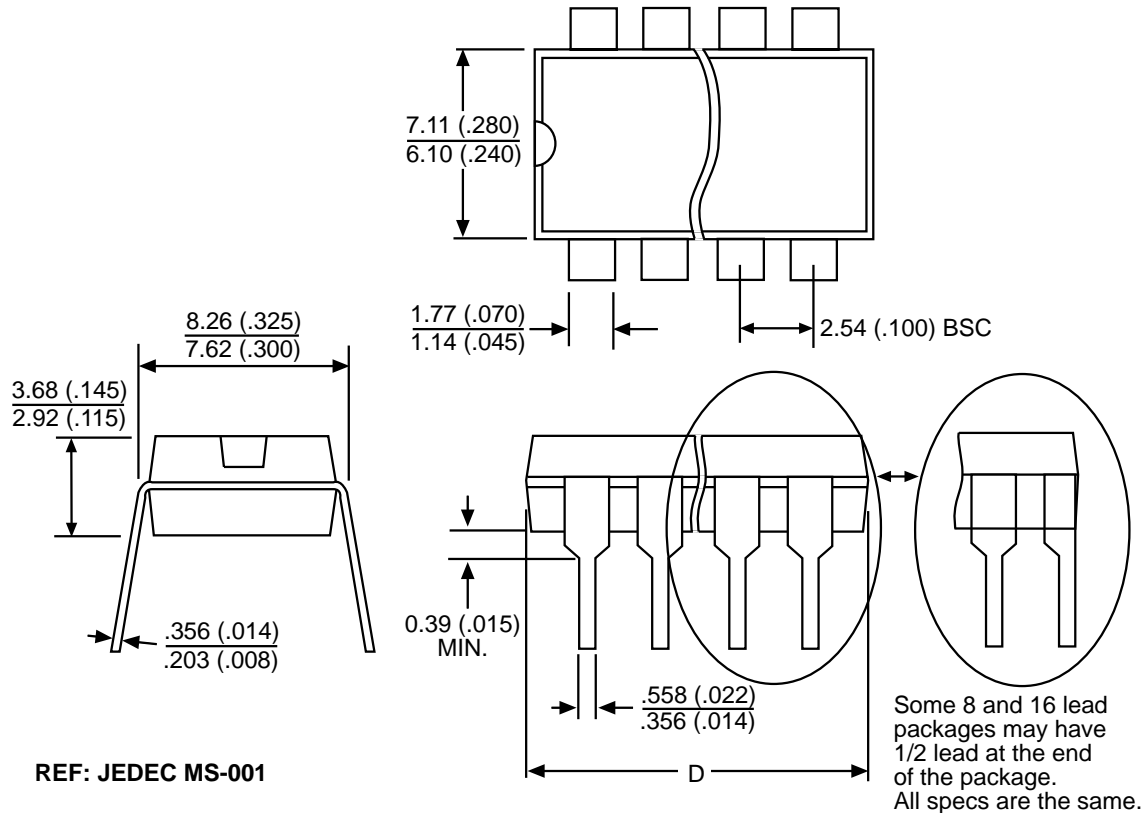

Ordering Information

Part Number	Description
CS4101EN20	20L PDIP

ON Semiconductor and the ON Logo are trademarks of Semiconductor Components Industries, LLC (SCILLC). ON Semiconductor reserves the right to make changes without further notice to any products herein. For additional information and the latest available information, please contact your local ON Semiconductor representative.